

CAD FILE:

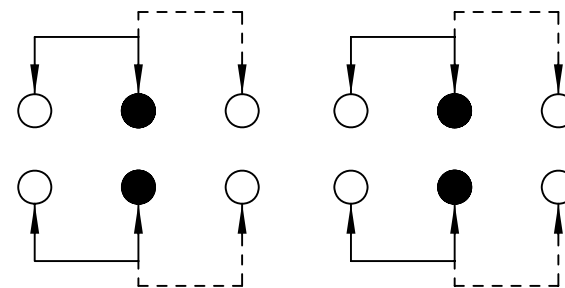

SCHEMATIC (NON-SHORTING)

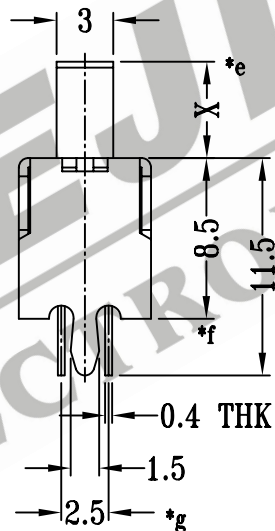
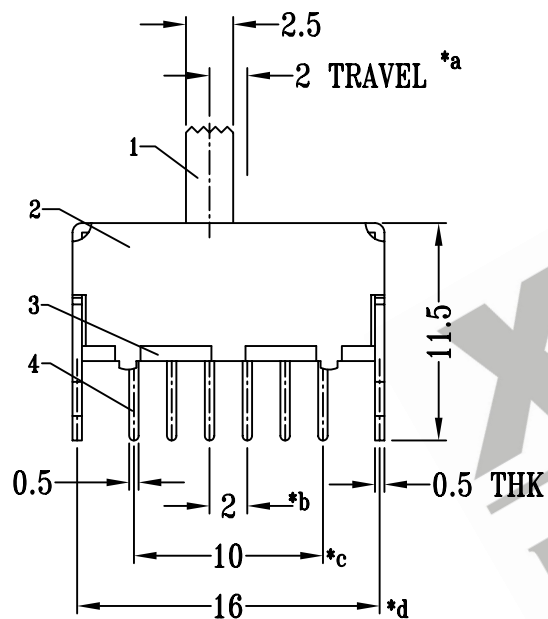
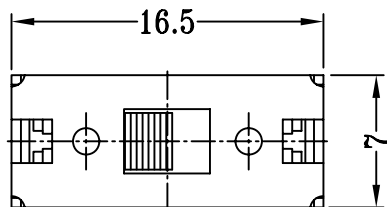
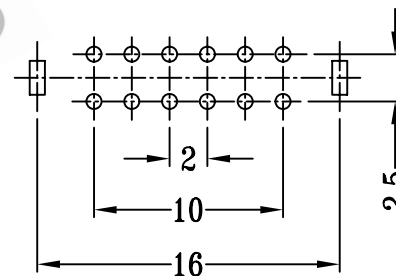

P.C.B LAYOUT

注：“*”表示关键尺寸（7个）

NO.	PARTS	MATERIALS	QTY.	FINISH	TOLERANCE UNLESS SPECIFIED	SHENZHEN XIEJIA ELECTRONICS CO.,LTD.				
8										
7										
6	CONTACT CLIP	PBS	4	Ag CLAD	WITHIN: 1.5±0.1mm OVER: 1.5±0.2mm	ISSUE	DATE	DESCRIPTIONS OF REVISION		APPD.
5	SPRING PLATE	STAINLESS STEEL	1	NATURAL						
4	TERMINAL	BRASS STRIP	12	Ag PLATED OVER Ni PLATED	TITLE: VERTICAL SLIDE SWITCH	UNIT : mm	DRWG NO : XJ-DR-SS42D24-00			
3	BASE	PHENOLIC RESIN	1	NATURAL	MODEL: SS-42D24	SCALE : 5:2	DWN.	ZHOUYU	2005-5-20	
2	FRAME	STEEL STRIP	1	Ni PLATED			CHK'D	FANGYING	2005-5-20	
1	KNOB	POM	1	BLACK			APPD.	KANGXINAN	2005-5-20	
					ALL MATERIALS MUST BE COMPLIANT TO ROHS					